

Procedure to Install the New Autogap[®] components in ER-1225 and ER825 Brake with inverted Armature Hub

P-230-1
819-0376

Installation & Operating Instructions



Contents

Introduction	2
Kit Parts List	2
Disassembling Armature/Hub Assembly	3
Assembling the New Autogap	4
Warranty	Back Page

⚠ WARNING Failure to follow these instructions may result in product damage, equipment damage, and serious or fatal injury to personnel.

Introduction

This instruction sheet provides detailed instructions for the replacement of existing autogap assemblies with new design autogap assemblies on Warner Electric® ER brakes for Montgomery-Kone®

Note: Please review the entire installation procedure prior to starting any work.

⚠ WARNING Please follow these instructions carefully to ensure proper operation. Failure to comply with these instructions can result in damage to property and injury or even death to personnel.

⚠ WARNING Applying power to the brake will release its hold on the escalator and may allow it to move. To prevent escalator movement and the damage and/or injury that may result, the escalator must be held in place by another means.

⚠ WARNING Keep fingers clear of the air gap area between the magnet (item 11) and the armature (item 3) - as the armature will be pulled sharply toward the magnet after the gap between them is closed to approximately 1/8 inch. See Figure 1. Injury can result if fingers are pinched between the armature and magnet.

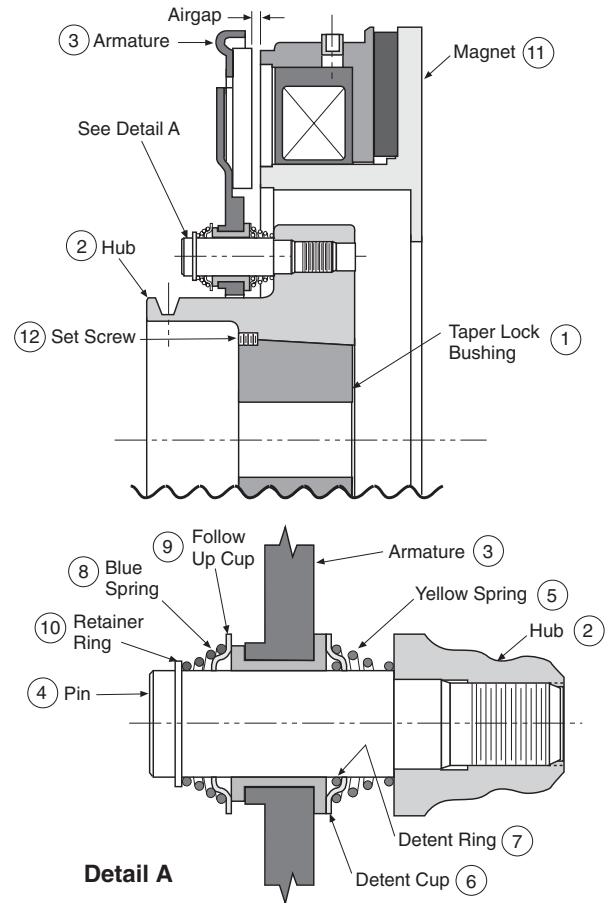

Figure 1

The kit part number for ER-825 is 5250-101-008 and for ER-1225 is 5252-101-005. The kit includes the following parts.

Kit Parts List - See Figure 3

Name	(Item No.)	Model 825 (Qty)	Model 1225 (Qty)
Pin & detent assembly	4 & 7	3	4
Detent Cup	6	3	4
Yellow Conical Spring	5	3	4
Red Straight Spring	8	3	4
Follow Up Cup	9	3	4
Retainer Ring	10	3	4
Instruction Manual		1	1
Claim Form		1	1

Tools required (not included)

- 1/4" Hex key wrench for taper lock bushing set screws – ER-1225.
- 3/16" Hex key wrench for taper lock bushing set screws – ER-825.
- 5/16" Hex key wrench for pins.
- 7/32" Hex key wrench for mounting screws.
- Tube Grade 242 Loctite.
- Snap ring pliers, external.
- Torque wrench minimum 200 lb.ft. reading – ER-825.
- Torque wrench minimum 400 lb.ft. reading – ER-1225.
- 3 steel shims, equal thickness, not less than 1/16", nor greater than 1/8".
- Small hammer (approximately 8 ounce).
- Drift

Disassembling the Armature/Hub Assembly (See Figure 1)

▲CAUTION Do not pry the armature away from the magnet. If armature is distorted the entire brake must be replaced.

Note: Steps (1) and (2) are to be performed at the motor and (3), (4), (5), (6) and (7) are to be performed on a bench away from the motor.

Note: Make sure power to the brake is turned off. See Figure 1 for the following seven steps.

Step 1: Loosen the taper-lock bushing (item 1) on the motor shaft.

To loosen, remove both set screws (item 12) from the taper lock bushing (item 1) using a hex key wrench. Insert one set screw into the previously vacant hole in the taper lock bushing and tighten this screw until the bushing is loosened in the hub (item 2). If the bushing does not loosen, tap on the hub with a drift and small hammer.

Step 2: Apply power to the brake. The armature will then spring away from the magnet. If it does not, check electrical connections and release voltage per Montgomery-Kone® instructions. Remove taper lock bushing (item 1) and armature assembly (items 2 & 3) from the motor shaft. Set the bushing aside. Do not discard the bushing.

Step 3: Remove the retainer rings (item 10) from pins (item 4). Discard rings.

Step 4: Remove the blue conical springs (item 8). Discard them.

Step 5: Remove the follow-up cups (item 9). Discard them.

Step 6: Remove the armature (item 3) and set it aside.

Do not discard.

Step 7: Use hex key wrench to remove the four drive pins (item 4). Discard four pins together with four detent rings (item 7), four detent cups (item 6), and four yellow springs (item 5). Do not discard hub.

Note: Do not remove the magnet from the motor.

Assembling the New Autogap Components with the existing Hub and Armature

(See Figures 2, 3, 4, & 5).

Note: Steps 1 through 8 below are to be done on a bench away from the motor.

CAUTION During Steps 1 through 3, ensure that the detent ring (item 7) does not slide off the pin (item 4). Make sure the yellow spring (item 5) is not pinched between the pin (item 4) and the hub (item 2).

Step 1: Each new detent ring (item 7) is assembled on each new pin (item 4) at the factory. Ensure that each detent ring is approximately 7/8 inch away from the shoulder of the pin. If it is not, slide the detent ring into position as shown in Figure 2.

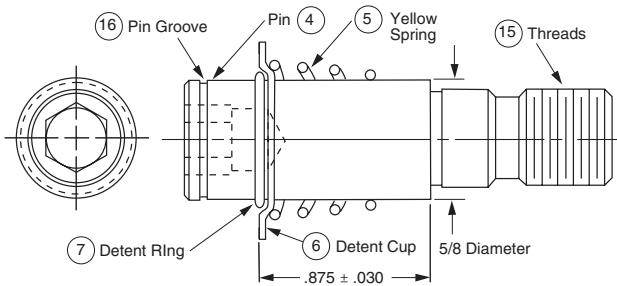

Figure 2

Step 2: Assemble each new detent cup (item 6) with concave side towards the detent ring (item 7) and each new yellow spring (item 5) onto each new pin (item 4) as shown in Figure 2. Make sure the small end of the yellow spring is on the 5/8 inch diameter as shown in Figure 2.

Step 3: Following the manufacturer's instructions, apply Grade 242 Loctite to each of the new pin threads (item 15) and, using the hex key wrench, screw the four new pins (item 4) into the hub (item 2). Tighten each pin to 45-50 lb.ft. of torque using a torque wrench.

CAUTION During Steps 4, 5, 6, 7 and 8, do not slam the armature down on the detent cups. Slamming the armature on the detent cups can deform the cups and cause the armature to rub during operation.

Step 4: Slide the previously saved armature (item 3) onto the pins, and **gently** push down on the armature towards the hub (item 2) until it bottoms out.

Step 5: Assemble each new red straight spring (item 8) onto each armature boss (item 13) as shown in Figure 3, Detail B.

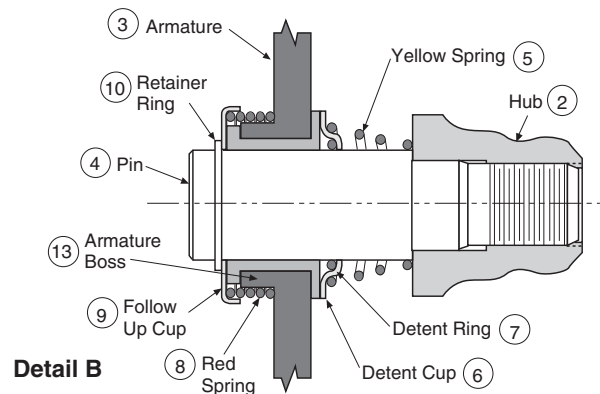
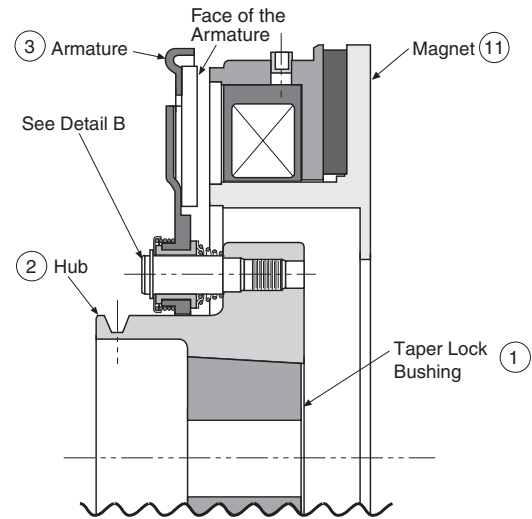

Figure 3

Step 6: Assemble each new follow up cup (item 9) over the pin and over the red spring (item 8) as shown in Figure 3, Detail B.

CAUTION Do not expand retainer ring (item 10) more than needed to slide over the pin (item 4). Expanding the retainer ring too far can cause it to yield or break.

Step 7: Assemble each retainer ring in the pin groove (item 16) as shown in Figure 2.

CAUTION Make sure the retainer ring is fully seated in the groove.

Step 8: Place the armature/hub assembly on a flat surface with the armature working face up and push down on each detent cup with fingers to slide the armature down until the armature can't be pushed down any further, as shown in Fig. 4.

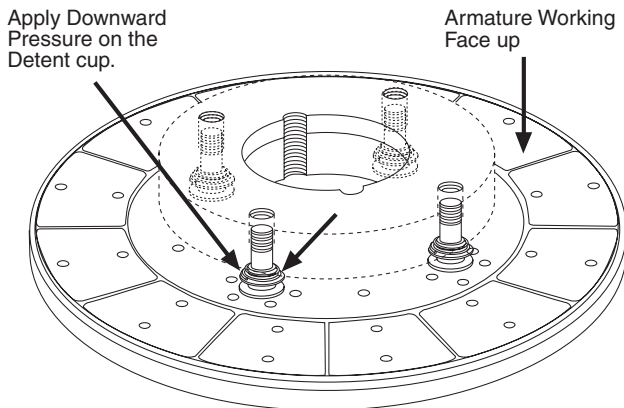

Figure 4

CAUTION During steps 9 through 11, handle the armature/hub assembly by the hub (item 2) only, making sure the armature (item 3) is as close to the retainer ring (item 10) as possible. Any movement of the armature on the pins will reduce available armature travel and may cause improper setting of the running air gap.

Note: Steps 9-15 below are to be performed at the installation site.

CAUTION .062 inch thick shims are recommended. Do not use shims thicker than 0.125 inch or you will shorten brake life by reducing available armature travel.

WARNING Keep fingers clear of the area between the magnet (item 11) and the armature (item 3) as the armature will be pulled sharply toward the magnet after the gap between them is closed to approximately 1/8 inch. See Figure 3. Injury can result if fingers are pinched between the armature and magnet.

Step 9: Turn off power to the brake. Place three steel shims 120 degrees apart on the magnet as shown in Figure 5. Insert the taper-lock bushing (item 1) into the hub (item 2). Align the two half drilled holes in the taper-lock bushing (item-1) with the two half threaded holes in the hub (item-2). Insert the two set screws into the above aligned holes & screw them loosely in by hand to maintain the alignment during assembly.

Slip the armature hub assembly onto the brake shaft until the armature makes contact with the shims. Place a drift at several points around the circumference against the large end of the taper lock bushing (item 1) and tap it lightly with a small hammer (approximately 8.oz), until it does not slide farther on the shaft.

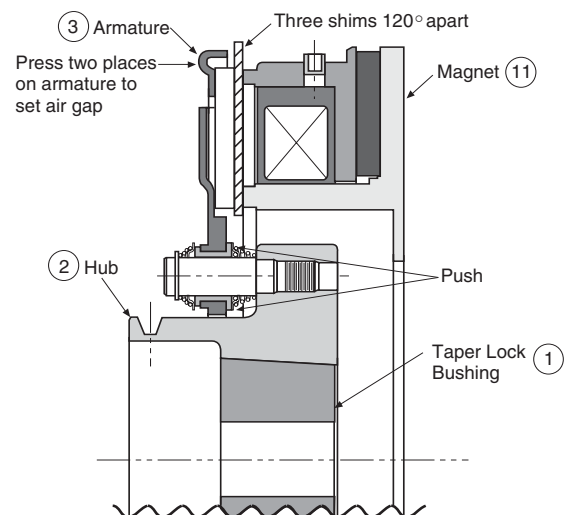

Figure 5

Step 10: Using a hex key wrench, tighten the hub bushing screws (item 12) alternately and evenly until tight. Using a drift, tap lightly at several points around the circumference against the large end of the bushing with a small hammer. Repeat this alternate tapping and re-tightening until the specified wrench torque no longer turns the screw after tapping. Tighten the screw to 15 lb.ft. torque using a torque wrench.

The airgap between armature and magnet must be .062 to .125 inch. If the airgap is outside of that range, reposition the armature hub assembly by repeating steps 1 and 2 of the disassembly procedure and steps 8, 9, and 10 of the assembly procedure.

Step 11: Apply power to the brake and remove shims. Set the airgap by pressing the armature into contact with the magnet and then releasing as shown in Figure 5. The armature should spring back approximately 1/32- 3/64 (.031-.045) inch. If the airgap is outside of that range, reposition the armature hub assembly by repeating steps 1 and 2 of the disassembly procedure and steps 8, 9, and 10 of the assembly procedure.

Step 12: Burnish the brake as follows: Start and stop the escalator 30 times. Allow 5-10 seconds delay between Start and Stop.

Step 13: Attach torque wrench to the end of the motor shaft. Hold the wrench at the handle, and pull it in the direction of motor rotation in one continuous motion (without any jerky motion) until shaft movement is detected. The highest reading on the dial is the static torque of the brake. This torque without any system drag must be at least 400 lb.ft. for ER-1225 and 125 lb.ft. for ER-825. If less, burnish the brake again, repeating step 12. If the brake does not meet the torque requirement after two burnishing procedures, replace the brake.

The brake installation procedure is now complete. If the brake is equipped with a tachometer, then reposition pulley if necessary and reinstall the belt. For electrical adjustments, see Montgomery Kone's Instructions. If any other components of the system were repositioned or disassembled, use appropriate instructions for their proper assembly or adjustments.

Warranty

Warner Electric LLC warrants that it will repair or replace (whichever it deems advisable) any product manufactured and sold by it which proves to be defective in material or workmanship within a period of one (1) year from the date of original purchase for consumer, commercial or industrial use.

This warranty extends only to the original purchaser and is not transferable or assignable without Warner Electric LLC's prior consent.

Warranty service can be obtained in the U.S.A. by returning any defective product, transportation charges prepaid, to the appropriate Warner Electric LLC factory. Additional warranty information may be obtained by writing the Customer Satisfaction Department, Warner Electric LLC, 449 Gardner Street, South Beloit, Illinois 61080, or by calling 815-389-3771.

A purchase receipt or other proof of original purchase will be required before warranty service is rendered. If found defective under the terms of this warranty, repair or replacement will be made, without charge, together with a refund for transportation costs. If found not to be defective, you will be notified and, with your consent, the item will be repaired or replaced and returned to you at your expense.

This warranty covers normal use and does not cover damage or defect which results from alteration, accident, neglect, or improper installation, operation, or maintenance.

Some states do not allow limitation on how long an implied warranty lasts, so the above limitation may not apply to you.

Warner Electric LLC's obligation under this warranty is limited to the repair or replacement of the defective product and in no event shall Warner Electric LLC be liable for consequential, indirect, or incidental damages of any kind incurred by reason of the manufacture, sale or use of any defective product. Warner Electric LLC neither assumes nor authorizes any other person to give any other warranty or to assume any other obligation or liability on its behalf.

WITH RESPECT TO CONSUMER USE OF THE PRODUCT, ANY IMPLIED WARRANTIES WHICH THE CONSUMER MAY HAVE ARE LIMITED IN DURATION TO ONE YEAR FROM THE DATE OF ORIGINAL CONSUMER PURCHASE. WITH RESPECT TO COMMERCIAL AND INDUSTRIAL USES OF THE PRODUCT, THE FOREGOING WARRANTY IS IN LIEU OF AND EXCLUDES ALL OTHER WARRANTIES, WHETHER EXPRESSED OR IMPLIED BY OPERATION OF LAW OR OTHERWISE, INCLUDING, BUT NOT LIMITED TO, ANY IMPLIED WARRANTIES OF MERCHANTABILITY OR FITNESS.

Some states do not allow the exclusion or limitation of incidental or consequential damages, so the above limitation or exclusion may not apply to you. This warranty gives you specific legal rights and you may also have other rights which vary from state to state.

Changes in Dimensions and Specifications

All dimensions and specifications shown in Warner Electric catalogs are subject to change without notice. Weights do not include weight of boxing for shipment. Certified prints will be furnished without charge on request to Warner Electric.



Warner Electric LLC
449 Gardner Street • South Beloit, IL 61080
815-389-3771 • Fax: 815-389-2582
www.warnerelectric.com